

- PLAN
- KESİT
- MODEL
- ODEON

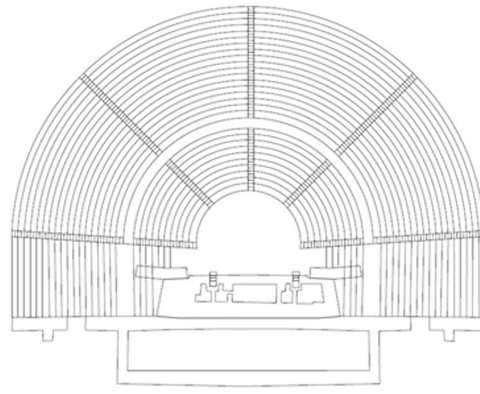

PLAN

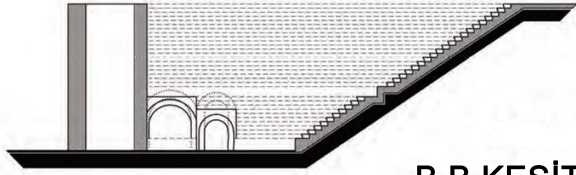

B.B KESİTİ

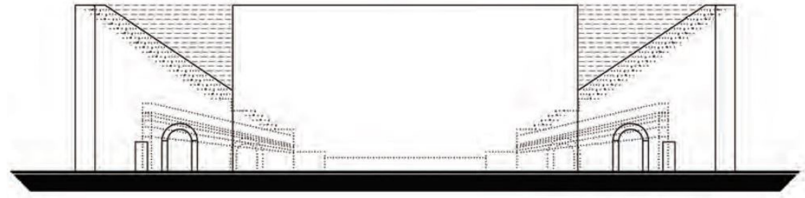

A.A KESİTİ

SKETCHUP MODEL FOTOĞRAFLARI

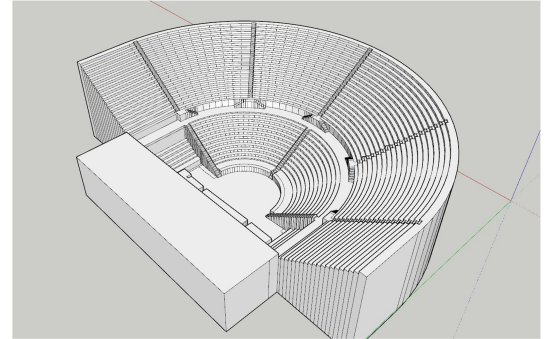
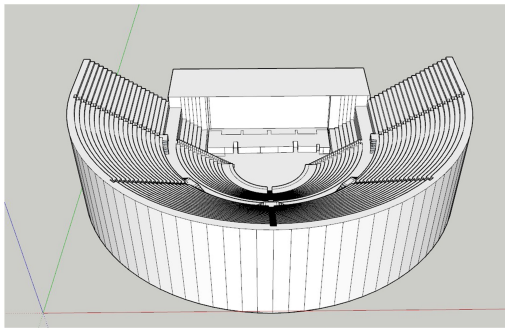
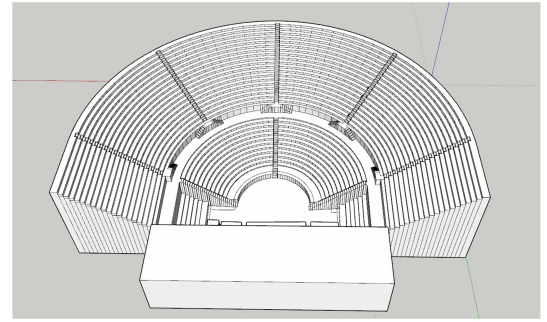
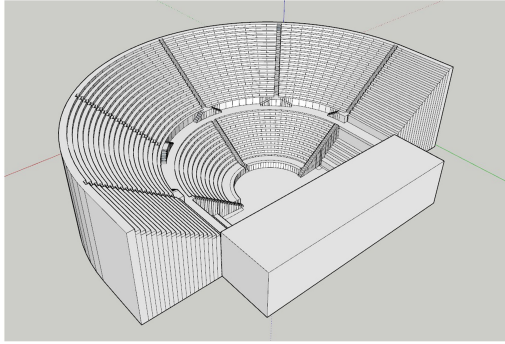

ODEON FOTOĞRAFLARI

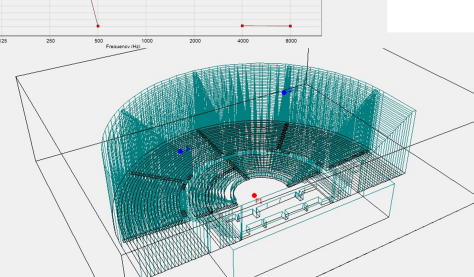
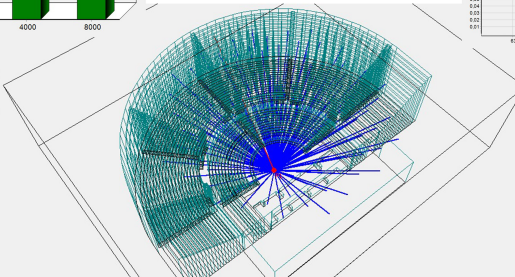
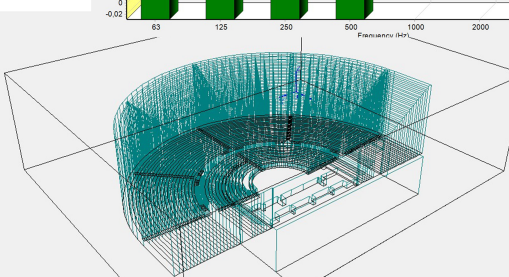
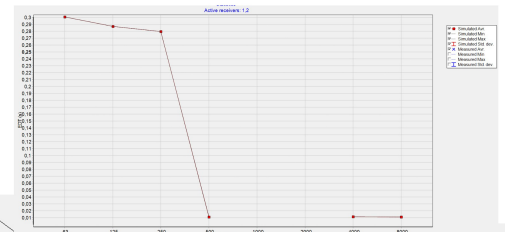
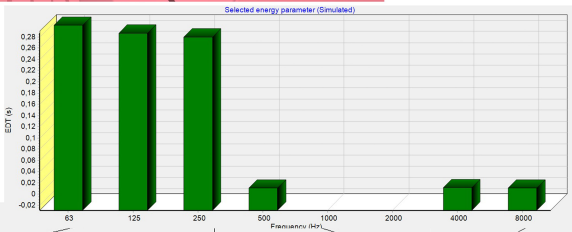
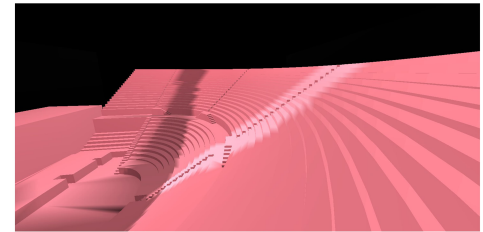
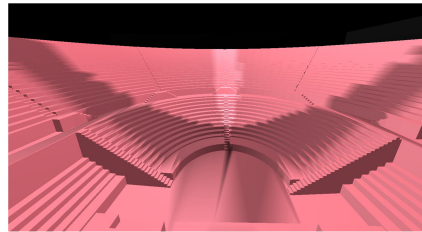
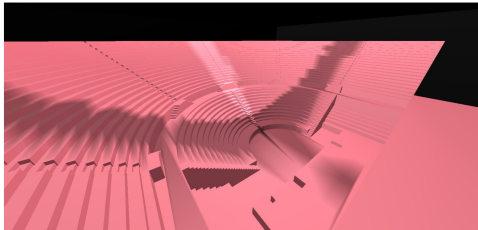

ANKARA ANTİK ROMA TİYATROSU

Ankara Roma Tiyatrosu, Türkiye'nin başkenti Ankara'da Altındağ ilçesine bağlı Ulus semtinde Hisar Caddesi ile Pınar Sokak arasında yer alan Antik Roma Tiyatrosudur. Yapım tarihi kesin olarak bilinmemekle birlikte MS 2. yüzyıla tarihlendirilmektedir. 1982 yılında bir inşaatın temel kazısı sırasında bulunan arkeolojik veriler neticesinde 1982-1986 yılları arasında Anadolu Medeniyetleri Müzesi öncülüğünde yapılan kazılar neticesinde ortaya çıkarılan yapı 25 Şubat 1992 tarihinde 1. ve 2. derece arkeolojik sit alanı olarak tescillendi. Yapılan kazılarda tonozlu parados binaları, döşemeli orkestra, seyirci oturma yerleri (cavea), sahne odasından arta kalan temel ve duvarların yanı sıra birçok heykel ve parçaları bulundu.



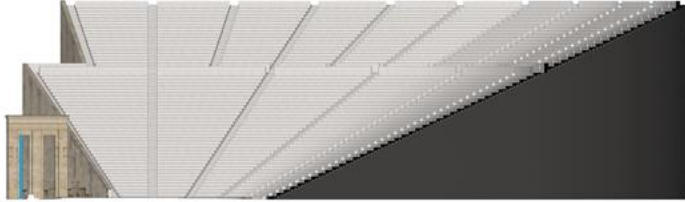
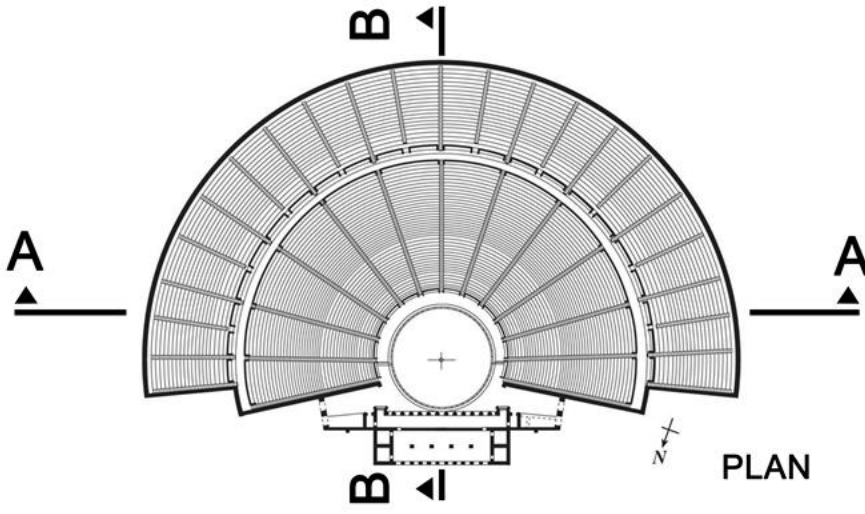

B.B KESİTİ



A.A KESİTİ

SKETCHUP MODEL FOTOĞRAFLARI

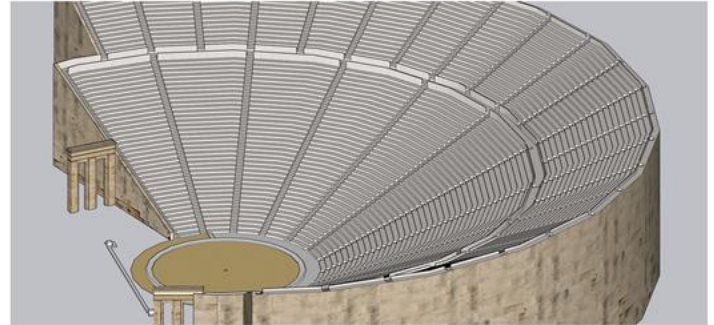
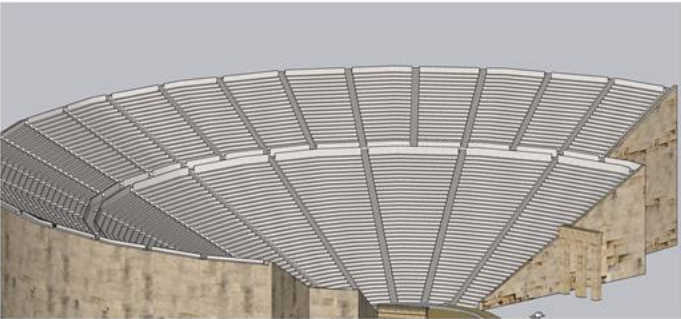
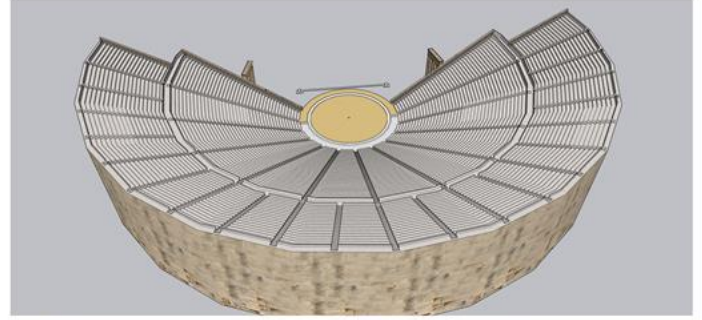
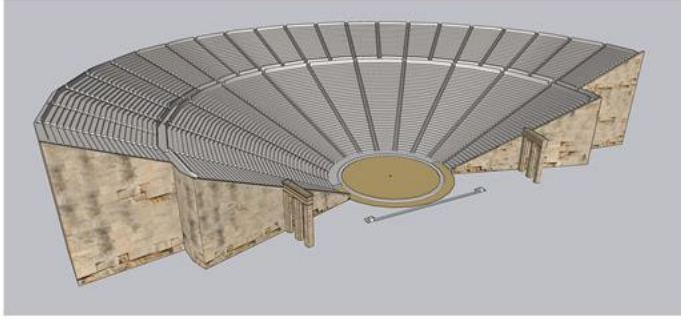

ODEON FOTOĞRAFLARI

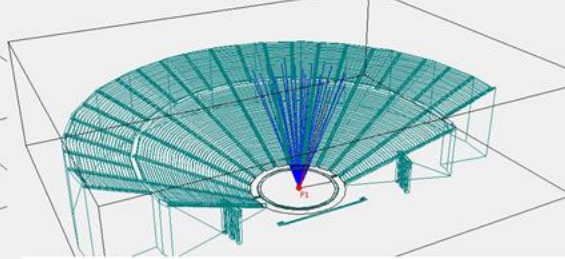
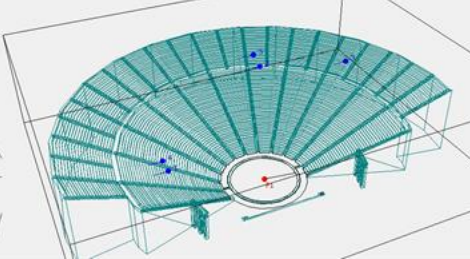
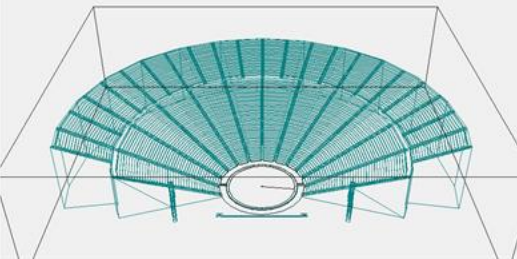
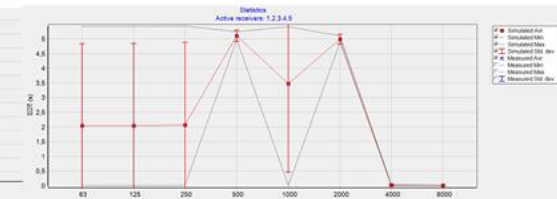
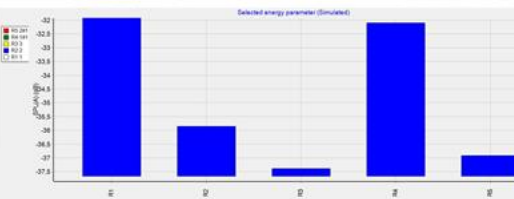
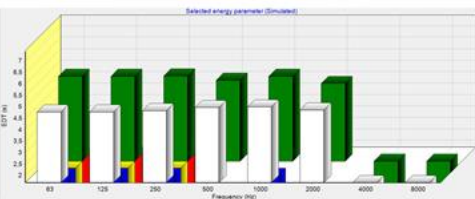
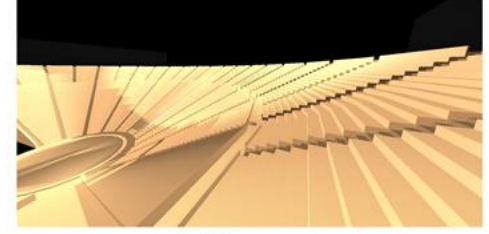
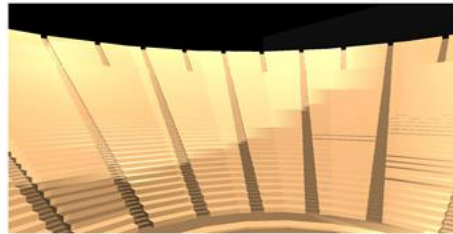
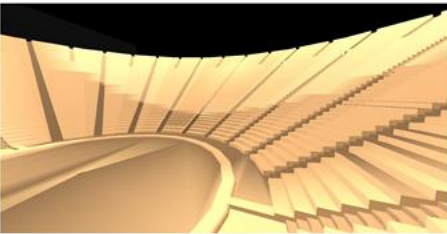

EPİDAUROS

ANTİK YUNAN TİYATROSU

Epidauros Antik Tiyatrosu, Mora Yarımadası'nda Epidauros antik kentinde bulunan antik tiyatrodur. M.Ö. 4. yüzyıla tarihlenen yapı, Atina'da Kynortion yanardağının yamacındadır. Günümüze kadar en iyi durumda gelen ve akustiği en iyi olan Antik Yunan tiyatrosu olarak kabul edilir. Mimarının Polykleitos olduğu sanılmaktadır. İlk defa Asklepiyon onuruna yapılan bir şenlikte kullanıldığı düşünülür. M.Ö. 2. yüzyılda yapılan değişikliklerle tiyatro son halini almıştır. 1881'de başlatılan arkeolojik kazılar sonucu ortaya çıkan yapıda 1938'den beri bu tiyatrodaki modern oyunlar sahnelenmektedir. Kimi araştırmacılar sahneden izleyicilere doğru esen rüzgârın, kimileri ise koltuk sıralarının eğiminin tiyatronun akustik başarısındaki ana unsur olduğuna dair teoriler ortaya atmıştır. Bazı araştırmacılar ise kireçtaşından yapılmış olan oturakların dalgali yüzeyinin tiyatronun akustiğinde rol oynadığını gösteren çalışmalar yapmıştır.

